

Intensive movement in wireless digital signal processing: from calculation to envelopment

--

Adrian Mackenzie

Room D22a, IAS Building

CESAGen - Centre for Social and Economic Aspects of Genomics

Lancaster University, LA1 4YD, UK

a.mackenzie@lancaster.ac.uk

ph (44) 01524 5910848

fax (44) 01524 594273

Intensive movement in wireless digital signal processing: from calculation to envelopment

Abstract: The paper broadly concerns the set of algorithmic processes associated with wireless networks known as 'digital signal processing' (DSP). By virtue of its labyrinthine technical complexity, wireless DSP is a worst-case scenario for social science research into software and code. This specific type of real-time computation, however, is vital to proliferation of wireless services, devices and products, and hence to the recomposing-shape-shifting urban spaces they inhabit. The paper addresses the problem of accounting for the convoluted nature of the DSP associated with wireless communication. It argues that we can only understand what is at stake in DSP by changing focus away from abstract understandings of code, calculation and software to specific design processes that fold new configurations of space and movement into wireless network signals. It argues that, at the moment, the ongoing dynamism of wireless networks could be just as important to understand as the altered modes of proximity, intimacy, co-location and distance associated with wireless technologies such as mobile phones, wireless networks, game controllers and remote controls. To this end, it frames wireless DSP in terms of *intensive movement* produced by a *centre of envelopment*. Centres of envelopment generate extensive changes, but they also change the nature of change itself.

Intensive movement in wireless digital signal processing: from calculation to envelopment

At the end of 2007, one billion IEEE (Institute of Electrical and Electronic Engineers) 802.11 or Wi-Fi® chipsets were in the world. One billion such wireless networking chipsets will be produced *each year* by 2012, according to market researchers (ABIResearch, 2007). Most of these little black boxes will not go into computers. Two thirds will make their way into a variety of electronic devices, especially consumer electronics and telephones, and many will vanish into wireless network infrastructures in cities, industrial and institutional facilities, and environmental sensor networks. Similar figures could be cited for other common forms of wireless networking (Bluetooth, 3G and WiMAX). Moreover, the extent of these networks is growing very rapidly in a great variety of different places, not least in developing countries such as Vietnam, Rwanda, and India where the latest wireless technologies are often tested. In response to the tremendous growth in digital signal processing hardware, this paper asks two related questions. Firstly, it asks: from what kind of spatial, economic, and cultural processes do these chipsets and the code they execute derive? Secondly, it highlights the functioning of code and algorithms in the production of wireless space in order to ask: how do digital signal processing algorithms assemble or generate space? Wherever these chips end up, the way the world hangs together, its spacing, is affected by the numerous relations that such wireless devices

sustain.

It turns out that the digital signal processing techniques used in quite different, often competing wireless networks are broadly similar. Discussion here centres on some key computational processes at work in the now common 802.11 or Wi-Fi networks as well as in other wireless technologies such as WiMax (Worldwide Interoperability for Microwave Access) and 3G, 3.5G and 4G mobile phone wireless networks. This broad similarity of code architecture across difference scales and domains suggests that they respond to a common problem. At the one level, the problem is this: while the State can fence off wide swathes of electromagnetic spectrum for exclusively military use, civil society and commerce has to work out how to co-habit narrow bands of spectrum. In contrast to fibre optic cable and copper twisted pair, which can be fully owned and operated privately, the limited spectrum made available by States to wireless networks needs to be habitable by many. This is a basic problem to which a truly kaleidoscopic range of signal processing techniques respond. However, the regulatory control over spectrum continues to treat it as a resource like land or territory, something to be enclosed and divided into different parcels. Crucially, for the purposes of my argument, the treatment of spectrum as territorial space by States and in international agreements triggers a convoluted series of technical and legal manoeuvres. Indeed as (Hugill, 1999, 123) suggests, the State's habit of restrictively allocating spectrum has led to efflorescences and outcrops of wireless activity in the past (for example, international wireless communication was developed by amateurs in the 1920s using high-frequencies that the US government, the Navy in particular, had thought to be militarily and commercial useless).

The technical details of contemporary wireless DSP can be baffling. This will affect readers

of this paper differently. Some will perhaps find the attempt to make sense of the code architecture of wireless DSP pointless. However, the foray into DSP code architecture answers a particular problem: social science researchers who want to develop a sense of transformations in movement and space associated with code need to somehow sift out important elements of that detail. This has been quite widely acknowledged already.

Stephen Graham asks, for instance,

Given the inevitably confidential, proprietary and highly technical nature of the core algorithms that now socially sort so many key social domains, what research techniques and paradigms can offer any genuine assistance here? Clearly, the research challenges here are considerable. This is especially so given that, from the point of view of social geographic research, the worlds of software-sorting tend not to be amenable in any meaningful way to traditional geographical or social scientific research techniques and conceptualizations. (Graham, 2005,576)

(Similar questions motivate the emerging sub-field of software studies: see (Fuller, 2007, Fuller, 2003, Mackenzie, 2006). In contrast to the more obviously politically loaded algorithms of face recognition, data-mining, or even GIS, the algorithmic processes in DPS offer a strong challenge for research. They present themselves in highly packaged, convoluted forms, so it is difficult for the researcher to see their relation to political economies of telecommunication. Moreover, in their somewhat stunning complexity, they seem to bear only a tangential relation to the powerful dynamics of belonging, participation, separation and exclusion typical of contemporary network cultures. Bearing these difficulties in mind, if this paper could achieve one thing, it would be to render slightly more visible the dynamics that convolute wireless signal processing, and to suggest how these dynamics envelope movement, sensing, being present to or apart from others. At core, although this argument needs to be developed on a larger scale (see (Mackenzie, 2009)), the underlying issue is a struggle over different material experiences

of freedom today.

Background noise: from spectrum as homogeneous space to air as coded space

Using a vast spider-web of an antenna, the very entrepreneurial Guglielmo Marconi claimed that he received the three letters 'SSS' transmitted from Poldhu in Cornwall, England at St John's, Newfoundland on 12-13 Dec, 1901 (Hong, 2001, 54-55). The immense apparatus at Poldhu emitted quite powerful, chaotic or 'dirty' long wavelength, low frequency electromagnetic discharges (25 kilowatt pulses). By today's regulatory standards, they would certainly be illegal because they were 'broadbanded' or untuned (Aitken, 1985, 216). Some scholars today argue that he may well have mistaken atmospheric noise for a morse code message (Aitken, 1985, 265) or that his 'untuned kite' could not possibly have received the low frequency message (Hong, 2001, 213). Whatever happened on that day, Marconi's 'error' and its chaotic discharge of energy is that one that much of the algorithmic complexity of contemporary wireless chips seeks to minimise. Jumping a century from Marconi's wireless telegraphy to wireless information and communication networks, we are confronted today with a much more heterogeneous socio-technical assemblage. The electromagnetic spectrum is incredibly densely populated in some places. A chart of U.S. Spectrum allocation shows several hundred different uses of radio waves (National Telecommunications and Information Administration, 2003). Although the antennas, even the radio frequency amplifiers are similar in principle, the algorithmic complexity of wireless networks looks very different from the digital morse code Marconi. A tightly packed labyrinth of digital signal processing lies between antenna and what reaches our eyes and ears. Chipsets, produced by Broadcom, Intel, Texas

Instruments, Motorola, Airgo or Pico, are tiny ($<1 \text{ cm}^2$) fragments that support highly convoluted and concatenated paths on nanometer scales. In wireless networks such as Wi-Fi, Bluetooth, and 3G mobile phones with their billions of miniaturised chipsets, we encounter a an intricately engineered signal envelope.

What is at stake in these convoluted, compressed packages, these densely organised spaces of movement? Take for instance the picoChip, a latest-generation wireless digital signal processing chip, designed by a 'fabless' semiconductor company, picoChip Designs Ltd, in Bath, UK, not too far from Pouldhu in Cornwall. The product brief describes the chip as

[t]he architecture of choice for next-generation wireless. Expressly designed to address the new air-interfaces, picoChip's multi-core DSP is the most powerful baseband processor on the market. Ideally suited to WiMAX, HSPA, UMTS-LTE, 802.16m, 802.20 and others, the picoArray delivers ten-times better MIPS/\$ than legacy approaches. Crucially, the picoArray is easy to program, with a robust development environment and fast learning curve (PicoChip, 2007).

Written for electronics engineers, the brief highlights that the chip is designed for 'the new air-interfaces.' To this end, it accommodates a variety of wireless communication standards (WiMAX, HSPA, 802.16m, 802.20, etc). The promises of high performance and low cost are no surprise. Many electronic product briefs offer that. In this case, the chip combines computing performance and value for money ('ten times better MIPS/\$' - Million of Instructions Per Second/\$) as a 'baseband processor.' That means that it could find its way into many different version of hardware being produced for applications that range between large-scale wireless information infrastructures and small consumer electronics applications. Only the last point is slightly surprisingly emphatic: '[c]rucially, the picoArray is easy to program, with a robust development environment and fast learning curve.' Why should ease of programming be important? If ease of programming

is so important, we can only conclude that the code produced by programming matters to wireless DSP in some way. This code entails lots of computations (hence the claim to high MIPS/\$). And this computation is all in the service of the 'new air interfaces.'

Architectures of air

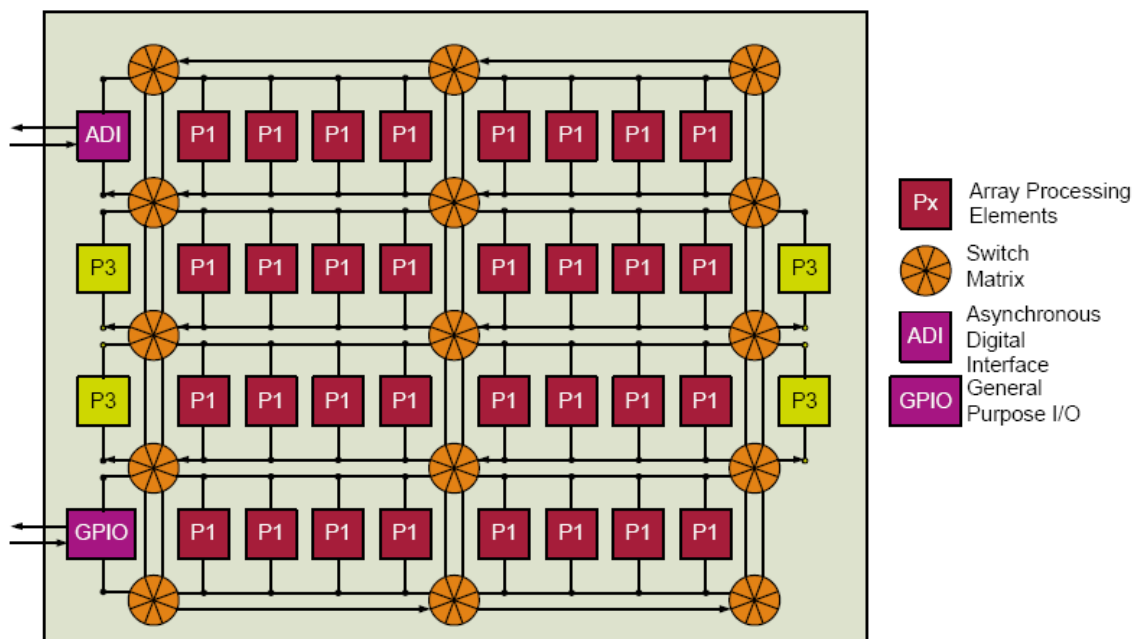

Figure 1: typical contemporary wireless infrastructure DSP chip architecture PicoChip202 (PicoChip, 2007)

Whatever code is to be found on the picoChip, we are witnessing, as Nigel Thrift writes, 'a major change in the geography of calculation. Whereas "computing" used to consist of *centres of calculation* located at definite sites, now, through the medium of wireless, it is changing its shape' (Thrift, 2004, 182).¹

¹ A centre of calculation is, according to Bruno Latour, any site where inscriptions are combined and make possible a type of calculation. It can be a laboratory, a statistical institution, the files of a geographer, a data bank, and so forth. This expression locates in specific sites an ability to calculate that is too often placed in the mind Bruno Latour, *Pandora's Hope : Essays on the Reality of Science Studies* (Cambridge, Mass.: Harvard University Press, 1999)..

The architecture of the picoChip [Figure 1] refers to that shifting ground, to air, so to speak. The picoChip's 'multi-core' architecture, as a rather manic multi-centred site of calculation, supports many types of calculation concerned with what happens in air. It stores data, it performs statistical reckonings, and it has co-processors and accelerators dedicated to specific calculation tasks. In their variety, the kinds of operation supported on the picoChip cannot be reduced to a single class of operations, or to calculation in general.² While I turn to some of the specific code operations below, here it is useful to observe that the architecture of the picoChip is also symptomatic: it seeks to make a constant re-shaping of computation possible, normal, affordable, accessible and programmable. Hence the geography of calculation, as typified in the picoChip does more, I would argue, than change the shape of computing. It makes change in the shape of computing into an operational feature. The picoChip is designed for constant change. This is the effect of a more intensive, and enveloping set of movements (that I am loosely, borrowing from the work of Gilles Deleuze, calling a 'centre of envelopment' (Deleuze, 2001)).

One form of this operationalisation of change exemplified in the picoChip occurs in its highly parallel architecture. Indeed, DSP is undergoing massive parallelisation: more chips everywhere, and chips that do more in parallel. The advanced architecture of the picoChip is typical of the shape of things: '[t]he picoArray® is a tiled processor architecture in which hundreds of processors are connected together using a deterministic interconnect. The level of parallelism is relatively fine grained with each processor having a small amount of local memory. ... Multiple picoArray™ devices may be connected

2 A tendency to conflate all numbering, ordering, aggregation or assembling of multiples under a general concept of calculation vitiates the relevance of theoretical work on calculation such as Stuart Elden, *Speaking against Number: Heidegger, Language and the Politics of Calculation* (Edinburgh: Edinburgh University Press, 2006)..

together to form systems containing thousands of processors using on-chip peripherals which effectively extend the on-chip bus structure' (Panesar, et al., 2006, 324). The array of processors shown in Figure 1, then, could be read as representing part of a much more extensive diffusion of processors in wireless digital signal processing: in wireless base stations, 3G phones, mobile computing, local area networks, municipal, community and domestic wi-fi network, in femtocells, picocells, in backhaul, last-mile or first mile infrastructures. . There is global rise in the level of DSP blanketing cities, towns and landscapes in wireless technologies, but also in the DSP codecs that form the basis of contemporary audiovisual media (Mackenzie, 2008). Sometimes this extension of sameness is viewed as good. For instance, executives and engineers at the annual Mobile World Congress see it that way: we will all have more gadgets to accompany us around the world., and wherever those gadgets take us, they will connect, early and often. They will open the internet so that it becomes not only the WWW, but the internet of things (Sterling, 2005).

However, seen from a different angle, this proliferation of processors is more than an homogenising extension and diffusion of sameness. The interconnection between these arrays of processors is not simply extensive, as if space were blanketed by an ever finer and wider grid of points occupied by processors at work shaping signals. Against the tendency to see wireless DSP as an extension of sameness, I would suggest that we need to treat the code that connects these different processors as producing *intensive* movement (Massumi, 2002, 7). Intensive movement, in the sense used here, means movement that cannot be indexed or referenced to anything apart from itself (such as the point of reference, geographical coordinates, or spatial dimensions used to gauge extensive

movement). This might seem a strange claim to make, given the discussion of how wireless DSP responds to confined spectrum allocation and the crowding of spectrum. Would not spectrum regulation or indeed the consumption practices of the city be the frame of reference for wireless DSP? I would argue that complexities of code in wireless DSP does indeed respond to the incompatibilities and mismatches between spectrum allocation and inhabited space.

From this perspective, the massive parallelisation of wireless DSP is only a 'back-formation,' as Brian Massumi would call it, of intensive movement or change in process (Massumi, 2002, 7).³ The proliferation of paths and connection between parallel processors offered by the 'easy programmability' of the picoChip responds to a relational problem. The crux of this relational problem is indeed spatial, but also irreducible to an any pre-given space: how can many things (signals, messages, flows of information) occupy the same space at the same time in a way that preserves some degree of autonomy?

Were it not for digital signal processing, the problems of interference, of unrelated relations, would be potentially immense. With so many radio signals propagating, even strictly regulated by government licensing systems, the sheer diversity of wireless transmissions creates many kinds of new conjunctions and overlaps. On the one hand, governments and States control spectrum allocation to prevent interference between civilian and military communications. On the other hand, civilian spectrum is congested with mass media, organisations and individuals all wanting to transmit and receive

3 Massumi writes: 'Extensive space, and the arrested objects occupying the positions into which it is divisible, is a back-formation from cessation. The dynamic enabling the back-formation is "intensive" in the sense that movement, in process, cannot be determinately indexed to anything outside of itself' Brian Massumi, *Parables for the Virtual* (Durham, N.C: Duke University Press, 2002)..

signals. Spectrum becomes a valuable, tightly controlled resource. For any one communication, not much space or time seems to be available. And even when there is space, it may be noisy and packed with other people and things trying to communicate. Signals may have to work their way through crowds of other signals to reach the desired receiver. Communication does not take place in open, uncluttered space. It takes place in messy unplanned congeries of buildings, things and people, which obstruct waves and bounce signals around. The same signal may be received many times through different echoes ('multipath echo'). Because of the presence of crowds of other signals, and the limited spectrum available for any one transmission, wirelessness needs to be very careful in its selection of paths if experience is to stream rather than just buzz, as it may have done for Marconi in 1901.

In contrast to the early 20th century, the problem for wireless communication is not to blaze some high-wattage trans-Atlantic path, but to micro-differentiate many paths and to allow them to interweave and entwine with each other. This envelopment of micro-differentiated radio-space-time differs markedly from the high-level view of wireless space as populated by evermore extensive arrays of processors. We can see the programming of the array of processors on picoChip as a response to a problem of relationality induced by the presence of many others. In other words, this architecture, and the code that shapes it, is a form of sociality, albeit one that is difficult to see directly.

Wireless algorithms as forms in movement

The 'crucial' advantage offered by the picoChip is 'ease of programming.' But programmed to do what? In the case of wireless networks, the technical complexity of the programming deflects ready understanding of how digital signal processing (DSP)

algorithms organise spatial relations. In many devices, the code has already been etched *in silico*. In science and technology studies, researchers study science or technologies in the making in order to see how different interests or relations enter into the construction of the device or system. But commercial wireless chipsets such as the Broadcom 'BCM4325 Low-Power 802.11a/b/g with Bluetooth® 2.1 + EDR and FM' (Broadcom Corporation, 2007) are not 'in the making.' They are black-micro-boxed. The chips with all their algorithmic density, function as components in consumer products made in their millions. They are relatively mature, non-controversial facts. They 'work,' more or less, with constant limitations, failures, and in the face of an ongoing churn in wireless standards that quickly undermines any stable operation. In this context, the picoChip is useful because it temporarily delays this downstream submersion of algorithms into commodity hardware. The 'array of processors' with its 'ease of programming' can be read as signalling to engineers who design and make wireless devices and systems that everything may constantly change, that standards will shift, but that with picoChip the engineer can keep up.

Say the picoChips end up in the manufacture of some kind of box installed in a home, or attached to an aerial in the city. There are an ever increasing population of boxes associated with wireless networks and communications. If anything accounts for the extensive array of the picoChip, it would be attempts to allow such boxes to inhabit and connect different kinds of lived and technical spaces such as the home ('indoors') and the infrastructure ('the cell'). Wireless DSP reflects the fact that boxes are jostling and vying with each other for space indoors or out. The DSP algorithms attest to crowding, overlap, interference, coverage, and overflow in space of the spectrum. In the picoChip, the

massive paralleling of processors suggests that many steps need to occur in order to make a viable wireless signal. Digital signal processing for wireless communication invokes a series of techniques to shape signals, and to slice and layer the space-time of radio communication to allow many signals to overlap and interleave. As yet, we have little understanding of just how far this reorganisation of spectrum can go, and what this reorganisation means for practices and feelings of movement, proximity, distance, or boundaries between inside and outside, public and private.

Along the way, wireless DSP disrupts any easy classification of equipment as either infrastructure or appliance. This is a key point. (Graham and Marvin, 2001) have pointed to the fragmentation of infrastructure in the context of neo-liberal service economies. With wireless DSP, we could say, a further splintering or corrosion of infrastructure as such occurs. Through DSP, communication infrastructure becomes both a branded object of consumption and a site of constant spatial recomposition. Take for instance, an advertisement for the 3G wireless boxes sold by a firm called ip.access. The name of the company suggests something related to the internet: ip is a fairly well-known acronym standing for 'internet protocol,' a low-level communication protocol now widely used in information networks (Galloway, 2004). Yet ip.access is not providing internet access as such. Rather, it sells equipment to mobile phone service providers. Here is the sales pitch:

The good news:
she loves your 3G services.
The bad news:
she's indoors.

Ever try getting 3G data into a home?

Ever see what happens to the quality of coverage in the entire cell when you do?

We're ip.access and we've solved the problem of serving 3G users when they're at

home.

(ipaccess, 2007)

They have solved 'the problem of serving 3G users when they're at home' by making a box called 'Oyster 3G':

Oyster 3G is the home access femtocell that delivers high-quality 3G spectrum into the home. Because it uses the customer's broadband it actually adds capacity to your macro network, improving service for everyone in the cell, indoors or out.

(ipaccess, 2008)

The Oyster 3G 'femtocell' blankets the battleground of convergence, the home, with wireless cellular phone signals that connect to telephone networks through 'the customer's broadband.' Whether femtocells, picocells, nanocells, set-top boxes, wireless access points in the form of WiMAX or Wi-Fi win the battle for wireless spectrum in the home, and no matter what uneasy coalitions and truces between different forms of wireless connectivity eventually emerge, one thing is clear: the 'delivery' of wireless spectrum is reorganising that particular fold of space-time known as 'radio spectrum' in the interests of network connectivity and service provision.

It would be relevant and important to catalog and compare some of the many different schemes, enterprises, activisms, markets and forms of regulation attached to contemporary wireless networking. Such schemes try to cultivate the 'good news' ('she loves your 3G services') and extinguish the 'bad news' (deterioration in 'coverage in the entire cell'). A political economy of wireless DSP would be able show how the patent pools owned by hardware manufacturers and equipment suppliers combine in the work of international organisations such as IEEE (Institute of Electrical and Electronic Engineers) to produce a constant stream of standardised code-specifications such as IEEE 802.11a, b, g, n (Wi-Fi) or IEEE 802.16 (WiMAX). These compete with standards such as

HSPA and LTE coming from telecommunications organisations such as GSM Association and its mobile phone operator members (GSM Association, 2008). However, in order to focus on intensive movement in wireless DSP, we need to ask something both more concrete and a bit awkwardly technical: how do signal engineers manage to write code so that devices that can actually work in ways that satisfy all the constraints and difficulties that a crowded signal spectrum poses?

In wireless communication today, one thing is given: nearly all transmissions are affected by the presence of other signals. Any receiver might pick up a range of signals at once, and not be able to disentangle them. For instance, during recent tests of WiMAX in Hong Kong, the wireless networks unexpectedly obliterated a satellite feed that has approximately 300 million viewers in China (Forrester, 2007). Even aside from such extreme cases, the relational effect is especially common in urban zones (but also in deep space missions that rely on DSP to communicate over vast distances mottled with stellar radio sources). Due to this crowding of signals, 'severe channel conditions' (a common wireless engineering term that does not describe bad weather between France and U.K., but any situation where propagating a clear signal is difficult; typically, a city street) often prevail in deep space and in cities. In cities and built environments, digital convergence and information industry means that more traffic has to move more quickly. The question of wireless sociality arises: how to transmit signals without destroying other people's possibility of transmission?

In general, we could say that wireless networks solve this problem by introducing forms of intensive movement, movement that cannot be indexed or referenced to other frames apart from the movement itself. It may not be possible to grasp the full significance or

implications of this mode of movement at the moment. However, it is important to recognise that the implications of this mode of movement are heavily contested (for instance, in the commercial competition for markets) as they reshape and re-texture experience. The technical process of shaping a signal so that it moves intensively cannot be complete or perfect. Just the opposite, it reflects a pragmatic pessimism about the possibility of a signal making it through intact. The signal processing needs to be accomplish the task of making sure that whatever has been lost can be re-constructed. Signal engineers pay a high cost in construing the world so pessimistically. Much effort has to be done to compensate for it, but the dividend is spaces that can be occupied by many at once, spaces that become intrinsically multiple.

The main design strategy underlying wireless DSP is somewhat counterintuitive. In contrast to previous electrical and electronic communications that sought make the signal strong and noise weak by tuning it as selectively as possible, contemporary wireless signal processing tries to make signals look as much like noise as possible. Noise, which we normally associate with the presence of others, and as parasitic or disruptive of communication is the basis of a the new density in signal sociability. Structured interference is a way of managing crowds in contemporary digital signal processing environments. The algorithms used in different versions of wireless networks such as Bluetooth, Wi-Fi, WiMAX, 3G, 3.5G and 4G all have this in common, even if the wireless technologies operate at different parts of the spectrum. The signal-as-noise has to be carefully structured or modulated so that it does not enter into relation with other signals, or in other words, so that it moves intensively. Various generic algorithmic techniques of multiplexing, transformation, compression and error-correction have been drawn from

many places – from audiovisual digital media, scientific computing, and many previous forms of communication and signal processing. The signal processing train that defines the physical form of specific wireless signal such as IEEE 802.11a (IEEE, 1999) or 802.11g (IEEE, 2003) is a mosaic of different processes linked with each other in a fixed order.

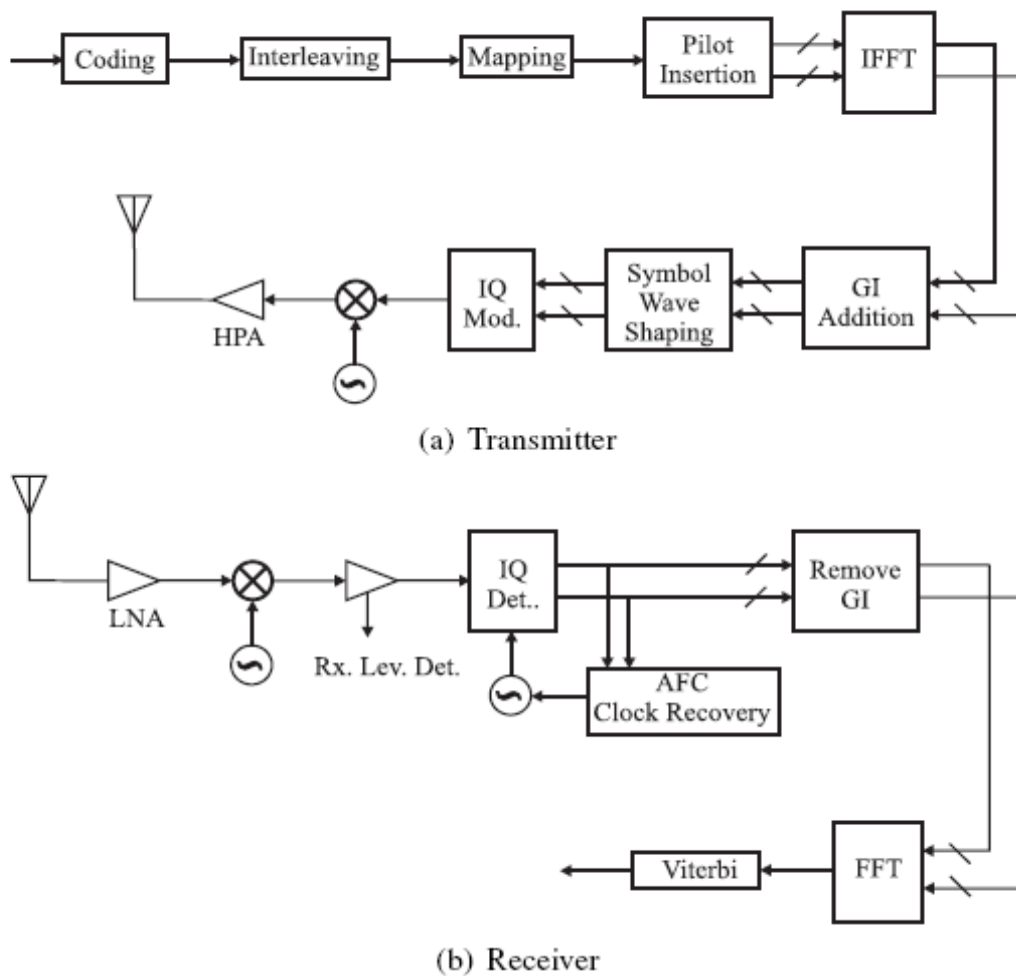

Figure 2: Concatenated algorithms in wireless computation (Akay and Ayanoglu, 2004)

The ways in which these different processes fit together in any given wireless technology determine the material specificity of the signal, and the kinds of relations it can sustain.

The linear sequence of steps shown in a signal processing architecture diagram does not

adequately convey the way in which different processes combine to structure a supple, filigree signal that can move through crowded environments, apparently without reference to intervening obstacles and interference. It is difficult for any diagram to represent how the different algorithms work together to effect communication in the physical layer. At the most, diagrams show a succession of steps, represented by boxes (see Figure 2). The set of steps sometimes give the impression of being a discrete sequence of operations on data to be communicated. However, it would be misleading to think of wireless communication as simply moving information (bits) through boxes that transform them into radio waves. The overall process of encoding-transmitting-receiving-decoding wireless communications embroiders and laminates information in multiple layers of modulation of the radio signal. Information is coded in a sequence of steps, but these steps take account of each other. Information is encoded, split, folded back together a number of times to allow a highly sinuous, yet permeable weave of relations to take hold internal to the signal itself. In order to grasp this compromise between strength and pliability, we need to how how the linear processing train diagrammed in Figure 2 maps onto the parallel processing array of the picoChip.

Intensive reorganisation of space

If we follow just one thread of this effort to fabricate an signal as intensive movement, we quickly find ourselves in the daunting technical labyrinth that underlies the promise of airy, weightless mobility of wireless communication. For instance, there are two algorithms deeply coupled in the construction of a wireless signal. These two - the convolutional-coding-Viterbi decoding phase - are typical of digital signal processing (see Figure 2). They form the 'inner' parts of the algorithms in 802.11a/b networks, the parts

that lie closest to the sources and receivers of information.

The Viterbi algorithm used by wireless receivers dates from 1967 (Viterbi, 1967). It is widely found in contemporary wireless networking standards such as Wi-Fi, WiMAX and 3G, 3.5G, and 4G. Andrew Viterbi, a now retired telecommunications engineer, designed the algorithm and started a company in California (Qualcomm, 2005) that designs and fabricates semiconductors based around the algorithm. This algorithm enables satellite, cellular phone and wireless networks to communicate despite high levels of electromagnetic noise.

Viterbi decoding starts from the premise that any signal it receives will certainly contain errors introduced by interference. For instance, in a 802.11 wireless network (IEEE, 1999) or a GSM cellular telephone network the data itself may have changed during transmission. A short burst of interference as someone hits a light-switch in the hallway upstairs may introduce errors in the datastream running between bedroom and living room. Stated more formally, when a signal is transmitted in the crowded electromagnetic environment of a city (or interplanetary space), the sequence of states that generates that signal is partially obscured or hidden. The Viterbi algorithm takes for granted that the sequence of system states that generated the signal at the transmitter cannot be directly observed. Instead, we can only hope to find the most probable *hidden states* that could account for the currently observed behaviour in a system. In general, the algorithm finds the most likely series of hidden states that could have given rise to the observed events, that is, the signal actually received.⁴ Already, a qualitative reorganisation has been

4 In the classifications of algorithms that computer science textbooks are fond of, the Viterbi algorithm is broadly regarded as a 'dynamic programming' algorithm Thomas H. Cormen and Thomas H. Cormen, *Introduction to Algorithms*, 1st ed. (Cambridge, Mass.: MIT Press, 1990).. This classification shows that the provenance of the Viterbi algorithm lies in 'operations research', a field of applied mathematics heavily developed in WW2 logistics. Dynamic programming developed as a paper-based logistics technique to

inscribed here that gives pause for thought. In the architecture of the Viterbi algorithm, the possibility of communication is put in question in certain respects. It removes part of the frame of reference of communication. It is assumed that we can only hope to determine the most probable series of sent signals. This assumption tends to decouple the propagation of the signal from the frame of reference of senders' intention or 'states'. This de-coupling is not complete, since it is still assumed that the sender was in *some* discrete state when it emitted a signal. However, the actual state is presumed hidden or removed.

What is a hidden state in this context? To answer this question in the context of wireless DSP, we need to move back to the transmitter. There, all data is encoded using 'convolutional coding' (represented by the box labelled 'Coding' in the top left of Figure 2).

The IEEE standards document for Wi-Fi 802.11b network instructs engineers thus:

The DATA field ... shall be coded with a convolutional encoder of coding rate $R = 1/2$, $2/3$, or $3/4$, corresponding to the desired data rate. The convolutional encoder shall use the industry-standard generator polynomials, $g_0 = 133$ and $g_1 = 171$, of rate $R = 1/2$ (IEEE, 1999, 16)

In convolutional coding, the computational processing capacity of the transmitter is used to build hidden states into the stream of information. It is very likely that some of the processors in the picoChip would be used to do this. When encoding the information, the transmitter adds extra bits to the sequence of data by applying a carefully chosen mathematical function, the 'generator polynomial' mentioned above in the 802.11b standard. 'Convolutional codes' get their name from the way in which they base what they transmit at the current point in time on what has been transmitted earlier. Via the

find shortest routes or paths through networks. A typical metaphor for explaining dynamic programming is the problem of how a tourist walking Manhattan could visit the most attractions with the least walking. Given the grid-like street layout, there are many different itineraries that pass by points of interest such as MoMA, the Empire State Building, Times Square, and Wall St. (Another version of the problem, a slightly older metaphor, is the travelling salesman problem. How can a travelling salesman visit all the towns in the region doing the least driving.

generator polynomial, they enfold a 'hidden state' describing the previous state into the current state. The 'convolution' folds information about what was transmitted previously into what is being transmitted now. A convolutional code endows the current state with memory of previous states. In this sense, a convolutionally coded signal contains hidden states. This memory effect injected by convolutional coding into the transmitted signal is destined for Viterbi decoders in the receivers. (Indeed, the picoChip supplies special 'hardware accelerators' for Viterbi decoding.) The Viterbi algorithm used in decoding a wireless signal latches onto the convolutional coding of the datastream as the hidden-states it can work with. Together, convolutional coding and Viterbi decoding weave durational strands in the signal that can withstand erosion by severe channel conditions. We can begin to see how the coupling of convolutional coding and the Viterbi decoding might not only be useful in communication systems whenever something obstructs access to what is actually transmitted in the present moment, and where many other signals are present. The convolutional coding - Viterbi decoding coupling reconfigures the problem of getting a signal through despite interference. It assumes the presence of others, and the vulnerability of all communication to delays and detours occasioned by them. Rather than trying to exclude the other, we could read these algorithmic processes as reconfiguring relations to others.

Centres of envelopment in wirelessness

This somewhat selective reading of wireless DSP through the convolutional encoding and Viterbi decoding algorithms yields a number of observations. Counter to the images of strict determinism sometimes associated with digital technologies or information systems, the collaboration between these two algorithms works to de-reference communication

probabilistically from an unpredictable and intrinsically dynamic environment. The need for a massively parallel programmable picoChip or the billions of Wi-Fi chipsets starts to become apparent. The application of processing power to wireless communication derives from the need to internalise within wireless signals models of space and time that are more supple or flexible than those of the abrasive environment the signal encounters. The coupling of convolutional coding, with its enfolding of previous states into the current state, and Viterbi decoding, with its highly optimised capacity to extract the most likely hidden states that have given rise to observed states, renders the information stream tolerant of interruption by others. Rather than perceiving information as purged, ethereal and error-free as some cyber-imagining does, wireless signal processing treats it as always buffeted, damaged, contaminated and in need of intensive work in order to move at all.

If we understand how this basic technical problem is solved, what comes of that? More important than understanding exactly how the technical problem of wireless communication is currently being solved by DSP code, the key consequence is that the DSP code brings heterogeneous conceptions of space and time into the data stream. This reorganisation of the signal allows it to inter-penetrate other signals without either being destroyed or altering them. Wireless signals today no longer populate the spatialized dimensions of frequency and wavelength of earlier radio spectrum. Although they have licensed frequencies, they permeate them diffusely and in inter-penetrating crowds.

Hence, the extension of wireless networks, their overlapping diffusion across landscapes, terrains, and environments on different scales ranging from centimetres to hundreds of kilometres, is accompanied by intensive movement achieved through internalisation of highly specific spatial and temporal processes.

If we draw back from the specifics of these algorithms, we can again address why it might be important to understand code as producing intensive movement. Following these movements, we have passed through a series of different boxes, each with its own frame of reference: from Oyster3G femtocell with its designs on home communication, to picoChip with its promise of easy programmability, from picoChip and picoArray processors to the signal processing diagrams for engineering standards such as IEEE 802.11 and IEEE 802.16 that seek to assemble and recruit many different, competing interests, and finally to specific algorithms such as Viterbi decoders and convolutional encoders programmed in programming languages such as C in order to de-reference signals from the contingencies of their medium.⁵ In various ways, this boxed labyrinth arises from the problem of how to co-habit the artificially confined and heavily populated slice of space known as wireless network spectrum.

Despite its analytical purchase on the power of action-at-a-distance, the centre of calculation concept does not offer purchase on the main dynamic here: the constant appearance of boxes on so many scales extends wireless networks, but also corresponds to an intensive movement. This dynamic does not produce boxes fitting more or less neatly inside each other, Russian Doll-style, as do centres of calculation. On the contrary, it produces boxes that jostle each other for space in urban environments, in the many varieties of wireless device appearing in homes, offices, and streets. The rapid fluctuations and turnover of wireless technologies, and even versions of the same technology (in the case of Wi-Fi), introduce a very different dynamic to the projective, stabilising movements

5 It would have been possible to go further with this un-boxing analysis, for instance, by discussing how hardware modelling languages such as VHDL (the Very High Speed Integrated Circuit Hardware Description Language Accellera, *Eda Industry Working Groups* (2007 [cited 15 October 2007]); available from <http://www.vhdl.org/index.html>.) allow engineers to describe the architecture of semiconductors using graphical and textual constructs such as boxes.

of centres of calculation. As well as setting up intensive movement, wireless DSP displays an alterability that might give us pause for thought. To tentatively address this dynamic we might say that centres of calculation today are replaced by *centres of envelopment*. The concept of a centre of envelopment a concept that Gilles Deleuze proposes late in *Difference and Repetition*, offers a way of understanding how extensive spaces arise from intensive movement. Such centres crop up when differences come into relation:

to the extent that every phenomenon finds its reason in a difference of intensity which frames it, as though this constituted the boundaries between which it flashes, we claim that complex systems increasingly tend to interiorise their constitutive differences: the centres of envelopment carry out this interiorisation of the individuating factors (Deleuze, 2001, 256).

What I have been describing as the intensive movement can be understood as an interiorising constitutive differences. An intensive movement always entails a change in the nature of change (Delanda, 2002, 61, Massumi, 2002, 7). In this case, a difference in intensity arises between the many formats of information (voice, video, text, images, data) characteristic of contemporary communications, the different patterns of everyday mobility of individuals and the highly constrained, State-licensed signal channels. The problem is how many such signals can move simultaneously without colliding, without interfering with each other: how can many more signals can pass by each other without taking up more space? These problems induce the compression and folding of spaces inside wireless processing, the folding that we might call a 'centre of envelopment' if only to emphasise that the extension of wireless technologies entails an interiorisation concretised in DSP. In contrast to centres of calculation defined by a fairly clear distinction between centre and periphery, centres of envelopment lead a more open-ended and convoluted existence. They entrain, include, recruit, and enfold heterogeneous spaces,

thus rendering the distinction between centre and periphery mobile. Their boundaries porous. The open-endedness of wireless DSP as centre of envelopment is a critical feature. Signal processing tends to organise multiply and repeat its actions across a spectrum of different situations. This occurs in a literal sense, as for instance, in the many commercial and public projects that invest in cutting-edge wireless networks such as WiMAX for developing countries.

Envelopment and alterability

One of the problems in analysing wireless DSP is that it seems to be somewhat implication-free. Unlike an algorithm for face recognition or a database schema for credit-checks, the algorithms for wireless DSP offer few recognisable social attributes or properties as handholds for critical analysis. It is hard, right now, to envisage a politics or social movements forming around wireless DSP. And yet, the proliferating chips and the mire of competing wireless technologies are something more than a reproduction of implication-free sameness of communication. There are signs that once closed, commercial infrastructures are being compelled to change in the wake of wireless technologies such as Wi-Fi. To understand the ongoing extension or diffusion of wireless networks in different zones and at different scales, we should pay attention to the dynamics of this alterability. It is difficult to do this without paying attention to what happens at the level of code.

A second layer of implication occurs in relation to infrastructure. In various ways, wirelessness puts the very primacy of extended infrastructure as foundation of lived space in question. Through DSP, signals seem to occupy the same space at the same time, something that should not happen in space understood as extended. It miniaturises infrastructure in a way that affects our sense of infrastructural scale. We can understand

this by re-conceptualising movement as intensive. Intensive movement occurs in multiple ways. Here I have emphasised the constant folding inwards or interiorisation of heterogeneous spaces or differences via algorithms used in digital signal processing.

Rather than propagating outwards, intensive movement in the form of the wireless DSP centres of envelopment borrows existing extended spatial orders: a logistics network, for instance, can end up inside the very bitstream. Intensive movement ensues when a centre of envelopment begins to interiorise differences. While these interiorised spaces are computationally intensive (as exemplified by the picoChip's massive processing power), the spaces they generate are not perceived as calculated, precise or rigid. Wirelessness is a relatively invisible, messy, amorphous, shifting set of depths and distances that lacks the visible form and organisation of other entities produced by centres of calculation (for instance, the shape of a CAD-designed building or car).

What of the ethico-political and methodological problems of making sense of the labyrinthine signal envelope? The 'ease of programmability' of the picoArrays, it turns out, might have less to do with the complications of the wireless algorithms, and more to do with engineers' need to constantly alter signal processing to re-align it on the shifting, sliding ground of competing wireless standards. The convolutions of signal processing attest to the complicated intersections of technology, built environments, capital, the State, and markets. If we want to understand the impetus, susceptibility and propensity for systems, places and processes to become wireless, then we need to track the constant introjection of ever more finely textured signals into smaller spaces via processes of envelopment. This introjection yields extensive movements as 'back-formations.' The algorithmic processes I have been describing here are not the only possible forms of

intensive movement, or the only way in which centres of envelopment affect differences. Further work is needed to understand how intensive movements are embodied at other points or sites in wirelessness.

Glossary

3.5G: a mobile phone technical standard that uses HSPA (see below) to provide broadband wireless to mobile phones.

3G: a mobile phone technical standard that offers more than voice telephone. For instance, it allows data transfer of image, graphics, text and video.

4G: a mobile phone technical standard (yet to be implemented) that will internet-protocol based voice, video and data connections.

IEEE 802.20: the Mobile Broadband Wireless Access Working Group seeks to develop a truly mobile wireless broadband standard. This is similar to IEEE 802.16e.

Air-interface: the radio-based link between mobile device and infrastructural base-station.

Backhaul: to transport traffic between an access point and a central point.

Bluetooth: a short-range or Personal Area Network wireless technical standard.

Compression: algorithmic technique of reducing the overall quantity of information transported.

Convolutional-coding: algorithmic technique of coding an information stream to allow error correction.

copper twisted pair: a form of wiring used in telephone lines where the twisting of

wires helps cancel electromagnetic interference from external sources.

DSP: algorithms that work on digital signals for the purposes of either analysing them or transforming them.

Error-correction: algorithmic techniques for reconstructing error-free data from noisy signal channels.

Fabless: a company that only designs and sells semiconductors, but does not actually make them.

Femtocells: a direct equivalent to a Wi-Fi access point, but for mobile cell phones.

Last mile: the distance between the backhaul infrastructure and homes.

HSPA: a set of standards for mobile cell phones that allow more efficient data transfer.

IEEE: an international standards body involved in developing standards for many telecommunications, electronics, biomedical and aerospace applications.

IEEE 802.11: a set of standards for wireless local area networks; generally known as Wi-Fi

IEEE 802.16: a set of standards for wireless metropolitan area networks; generally known as WiMAX.

LTE: Long Term Evolution, a technical standard for 4G mobile cell phones based on the core protocols of the internet.

MIPS: Millions of Instructions Per Second, a measure of computer processor speed.

multi-core: a CPU has that the more than one processing unit.

multiplexing: the technique of folding several signals into one.

physical layer: the lowest layer of internet protocols.

picocells: a small unit that provides cell phone coverage indoors.

picoChip: a multicore telecommunications DSP designed .

Viterbi decoding: a technique of error correction originally developed for deep-space communication.

Wi-Fi: a commercial brand name for IEEE 802.11-based communication equipment.

WiMAX: a commercial brand name for IEEE 802.16-based communication equipment.

References